

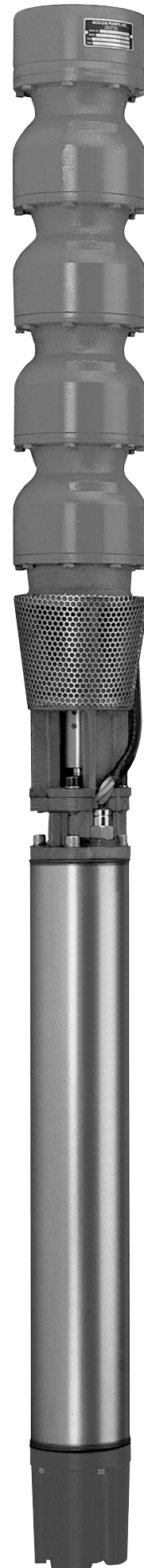

*A division of Layne Christensen Company*

# MODEL VS

Installation,  
Operation and  
Maintenance  
Instructions



## Foreward

This manual provides instructions for the Installation, Operation, and Maintenance of the Deep Well Turbine Pumps. This manual covers a standard product. For special options, supplemental instructions are available. **This manual must be read and understood before installation and start-up.**

This instruction manual covers several different pump models. Most assembly, disassembly, and inspection procedures are the same for all the pumps. However, where there are differences, these differences will be noted within the manual. The design, materials, and workmanship incorporated in the construction of the DWT Pumps makes them capable of giving long, trouble-free service. The life and satisfactory service of any mechanical unit, however, is enhanced and extended by correct application, proper installation, periodic inspection, condition monitoring and careful maintenance. This instruction manual was prepared to assist operators in understanding the construction and the correct methods of installing, operating, and maintaining these pumps.

The information contained in this book is intended to assist operating personnel by providing information on the characteristics of the purchased equipment. It does not relieve the user of their responsibility of using accepted engineering practices in the installation, operation, and maintenance of this equipment.

**Layne Christensen shall not be liable for physical injury, damage, or delays caused by a failure to observe the instructions for installation, operation and maintenance contained in this manual.**

**Warranty is valid only when genuine Christensen Pumps parts are used.**

Use of the equipment on a service other than stated in the order will nullify the warranty, unless written approval is obtained in advance from Christensen Pumps.

### **THIS MANUAL EXPLAINS :**

- Proper Installation
- Start-up Procedures
- Operation Procedures
- Routine Maintenance
- Pump Overhaul
- Trouble Shooting
- Ordering Spare or Repair Parts

## Owner's Information

Pump Model Number: \_\_\_\_\_

Pump Serial Number: \_\_\_\_\_

Control Model Number: \_\_\_\_\_

Dealer: \_\_\_\_\_

Dealer Phone No.: \_\_\_\_\_

Date of Purchase: \_\_\_\_\_ Installation: \_\_\_\_\_

Current Readings at Startup:

| 1 Ø          | 3 Ø          | L1-2  | L2-3  | L3-1  |
|--------------|--------------|-------|-------|-------|
| Amps: _____  | Amps: _____  | _____ | _____ | _____ |
| Volts: _____ | Volts: _____ | _____ | _____ | _____ |

## Table of Contents

| <u>SUBJECT</u>  | <u>PAGE</u> |
|---|-------------|
| Safety Instructions.....                              | 4           |
| Section 1 – General Information                       |             |
| Introduction.....                                     | 4           |
| Receiving and Checking.....                           | 4           |
| Materials and Equipment Required.....                 | 4           |
| Section 2 – Storage                                   |             |
| Storage.....  | 4           |
| Storage Preparation.....                              | 4           |
| Recommended Storage Procedures.....                   | 5           |
| Preparations for Uncontrolled Long-Term Storage.....  | 5           |
| Section 3 – General Description                       |             |
| General Description.....                              | 5           |
| Drivers.....  | 5           |
| Discharge.....  | 5           |
| Bowl Assembly.....                                    | 5           |
| Section 4 – Preparation for Installation              |             |
| Well Requirements.....                                | 6           |
| Preparing the Foundation.....                         | 6           |
| Motor and Cable Checks and Preparation.....           | 6           |
| Section 5 – Installing the Pump.....                  | 7           |
| Section 6 – Starting the Pump.....                    | 8           |
| Section 7 – Pump Disassembly and Reassembly           |             |
| Pump Disassembly.....                                 | 8           |
| Bowl Disassembly.....                                 | 10          |
| Turbine Bowl – Wear Rings Removal.....                | 10          |
| Turbine Bowl – Impeller Wear Ring Removal.....        | 10          |
| Bowl Bearing Removal.....                             | 10          |
| Inspection and Replacement.....                       | 10          |
| Turbine Bowl and Impeller Wear Ring Installation..... | 10          |
| Bowl Bearing Installation.....                        | 10          |
| Turbine Bowl with Taperlock – Reassembly.....         | 10          |
| Section 8 – Troubleshooting Chart.....                | 11          |
| Appendix A – Assembly of Pump and Motor.....          | 12          |
| Appendix B – Splicing Power Cable to Motor Leads..... | 12          |
| Appendix C – Electrical Tests.....                    | 13          |
| Limited Warranty.....                                 | 16          |

## SAFETY INSTRUCTIONS

**TO AVOID SERIOUS OR FATAL PERSONAL INJURY OR MAJOR PROPERTY DAMAGE, READ AND FOLLOW ALL SAFETY INSTRUCTIONS IN MANUAL AND ON PUMP.**

**THIS MANUAL IS INTENDED TO ASSIST IN THE INSTALLATION AND OPERATION OF THIS UNIT AND MUST BE KEPT WITH THE PUMP.**



This is a **SAFETY ALERT SYMBOL**. When you see this symbol on the pump or in the manual, look for one of the following signal words and be alert to the potential for personal injury or property damage.



**DANGER** Warns of hazards that **WILL** cause serious personal injury, death or major property damage.



**WARNING** Warns of hazards that **CAN** cause serious personal injury, death or major property damage.



**CAUTION** Warns of hazards that **CAN** cause personal injury or property damage.

**NOTICE: INDICATES SPECIAL INSTRUCTIONS WHICH ARE VERY IMPORTANT AND MUST BE FOLLOWED.**

**THOROUGHLY REVIEW ALL INSTRUCTIONS AND WARNINGS PRIOR TO PERFORMING ANY WORK ON THIS PUMP.**

**MAINTAIN ALL SAFETY DECALS.**

## SECTION 1 — GENERAL INFORMATION

### 1-1 INTRODUCTION

The design, materials and workmanship incorporated in the construction of Christensen Pumps submersible turbine pumps makes them capable of giving long, trouble-free service. The life and satisfactory service of any mechanical unit, however, is enhanced and extended by correct application, proper installation, periodic inspection and careful maintenance. This instruction manual was prepared to assist the operators in understanding the construction and correct methods of installing, operating and maintaining these pumps.

Study thoroughly Sections 1 through 8 and keep this manual handy for reference. Further information can be obtained by contacting Christensen Pumps sales office or your local branch office.



**Layne Christensen SHALL NOT BE LIABLE FOR ANY DAMAGES OR DELAY CAUSED BY FAILURE TO COMPLY WITH THE PROVISIONS OF THIS INSTRUCTION MANUAL.**

### 1-2 RECEIVING AND CHECKING

The pump shall be carefully supported prior to unloading from the carrier. Handle all components carefully. Inspection for damage of the shipping crate shall be made prior to unpacking the pump. After unpacking, visually inspect the pump and check the following:

1. Contents of the pump assembly against shipping list.
2. All components for damage.

Any shortages or damages should be immediately called to the attention of the local freight agent of the carrier by which the shipment arrived and proper notation made on the bill. This shall prevent any controversy when a claim is made and to facilitate prompt and satisfactory adjustment.

## 1-3 MATERIALS AND EQUIPMENT REQUIRED

The material and equipment necessary for installation of the pump will vary with the size of the pump and the type of installation. The following discussion and list of standard tools and supplies is therefore offered only as a guide.

### 1. BULK MATERIAL

Anti-galling lubricant, thread compound, lubrication oil, grease, petroleum based solvent.

### 2. HAND TOOLS

Pipe wrenches, two chains tongs and mechanic's hand tools.

### 3. INSTRUMENTS

One megger, or similar instrument indicating electrical resistance, clamp-on ammeter, voltmeter and a good grade of pipe joint compound should be available to facilitate assembly and possible future disassembly.

### 4. INSTALLATION EQUIPMENT

Wooden friction blocks or steel clamps, steel column lifting elevators of approved type and of proper size for the column pipe, and cable sling approximately 10 feet long of adequate size for the loads involved.

Although portable derricks are sometimes used, a properly designed pump setting rig is recommended. It must be possible to erect the crown block to a height so as to allow the load hook to be raised about three feet higher than the longest piece. The lifting device must be of sufficient strength and rigidity to raise the total weight of the unit safely.



**REMEMBER – REGARDLESS OF THE TYPE OF LIFTING EQUIPMENT, OR THE TYPE OF PUMPING EQUIPMENT, THE PRIMARY RULE IS: SAFETY FIRST.**

## SECTION 2 — STORAGE

### 2-1 STORAGE

Christensen Pumps carefully preserves and protects its products for shipment. However, the effective life of the preservatives applied at the factory can vary from 3 to 18 months depending on the severity of the environment in which the equipment is stored. This section provides procedures for preparation prior to storage and maintenance during storage of Christensen Pumps. These procedures are necessary to protect the precision parts of the pumps. Specific procedures for storing motors should be obtained from the motor manufacturer. This section is intended to be of general assistance to users of Christensen Pumps. It shall not modify, amend, and/or otherwise alter the scope of Christensen Pumps warranty in anyway whatsoever.

### 2-2 STORAGE PREPARATION

Christensen Pumps submersible pumps require proper preparation for storage. The pump shall be considered in storage when it has been delivered to the job site and

is awaiting installation. If a pump has been installed, but is not in regular operation, such as seasonal shutdown or an extended period of time, it is suggested that the pump be operated for at least 15 minutes every two weeks if possible.

### 2-3 RECOMMENDED STORAGE PROCEDURES

1. Controlled storage facilities should be maintained at an even temperature 10° F or more above the dew point with relative humidity less than 50% and little or no dust. (If these requirements cannot be met the pump is to be considered in uncontrolled storage.)
2. For uncontrolled storage periods of six months or less, the pump is to be inspected periodically to insure that all preservatives are intact.
3. All pipe threads and flanged pipe covers are to be sealed with tape.
4. The pump must not be stored closer than six inches to the ground.

### 2-4 PREPARATIONS FOR UNCONTROLLED LONG TERM STORAGE

Storage periods over six months require the preceding uncontrolled storage procedure plus the following:

1. Inspect the assembly and recoat periodically to prevent corrosion.
2. Place ten pounds of moisture absorbing desiccant or five pounds of vapor phase inhibitor crystals near the center of the pump. If the pump is assembled, place an additional one pound in the discharge nozzle securely fastened to the discharge flange.
3. Install a moisture indicator near the perimeter of the pump. Cover the pump with 6 mils minimum thickness black polyethylene or equal and seal it with tape. Provide a small ventilation hole approximately ½ inch diameter.
4. Provide a roof or a shed shelter to protect from direct exposure to the elements.

## SECTION 3 — GENERAL DESCRIPTION

### 3-1 GENERAL DESCRIPTION

Christensen Pumps model VS pump is a submersible turbine pump designed for maximum dependability. The VS pump also features capacities from 100 to 5000 GPM and larger, heads to 1000 feet. See Figure 1 for typical VS pump.

### 3-2 DRIVERS

Christensen Pumps furnishes only internationally recognized motors designed for continuous operation under any thrust which may develop throughout the performance curve. Impeller adjustment and type of coupling, splined or clamped, is dependent on the specific motor being used.

### 3-3 DISCHARGE

The discharge bowl provides an NPT or BSP thread for connecting to the well head or the first section of column pipe.

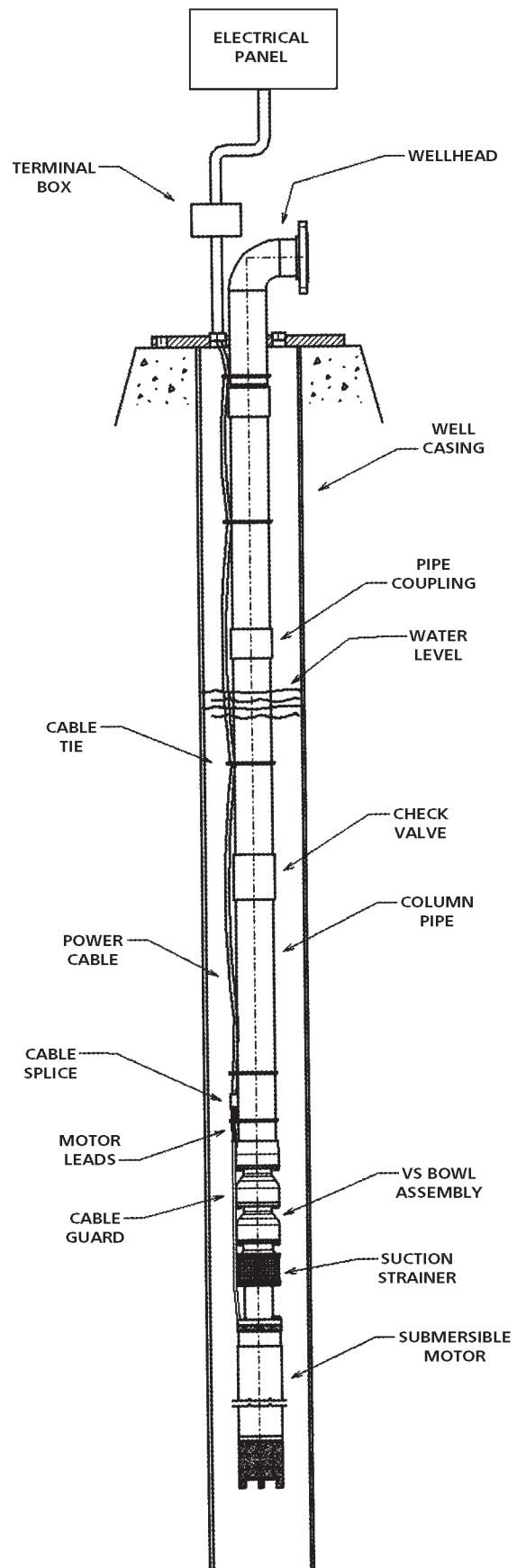

Figure 1 – Typical Submersible Pump Installation

### 3-4 BOWL ASSEMBLY

The bowls are generally flanged construction for accurate alignment and ease of assembly and disassembly. (Except 6DH model, which have threaded joints.) Impellers may be enclosed or open type. Impeller position is set at factory. No field adjustment is required.

## SECTION 4 — PREPARATION FOR INSTALLATION

### 4-1 WELL REQUIREMENTS

1. The well should be developed with a test pump prior to installing the submersible pump. Test pumping the well serves several purposes. It removes the excess sand encountered during the initial pumping of the well. Pumping sand or other abrasives with a submersible pump will shorten the life of the pump and can void the warranty.

**CAUTION** DO NOT INSTALL THE UNIT WITH THE MOTOR IN THE MUD, SAND OR RESTING ON THE BOTTOM OF THE WELL. IT IS IMPORTANT TO PREVENT THE WELL FROM SANDING UP AT ANY TIME TO THE POINT THAT THE MOTOR BECOMES EVEN PARTIALLY BURIED.

2. The test pumping also provides a means of determining the capacity and drawdown. The well capacity should equal or exceed the pump capacity. If the pump removes water at a higher rate than the well produces, the drawdown will be excessive and the pump will cavitate or 'starve' resulting in damage of the pump and motor.
3. The well must be deep enough so that the pump suction is at least 10 feet below the expected drawdown level. If the well screen or water producing aquifer is above the pumping level, the required submergence of the pump suction would be over 20 feet.

**CAUTION** NEVER INSTALL UNIT WITH THE BOTTOM OF THE MOTOR CLOSER THAN FIVE FEET FROM THE BOTTOM OF THE WELL.

4. The motor must always be immersed in **flowing water**. The flow rate must be over 1 ft./sec. If the pump is set below the well screen openings or other conditions exist that caused the water to be supplied from above the pump, a flow induce sleeve should be used.
5. The inside diameter of the well casing must be large enough to allow lowering the unit into the well without damage to the power cable, the splice between the power cable and the motor leads. Many wells have more than one size of casings installed and frequently the lower sections are smaller in diameter than the upper casing.
6. The submersible pump/motor unit must be operated in a straight portion of the well. Exerted pressures can and will cause misalignment of bearings or coupling. When the straightness of the well is not known, it is recommended to lower a test blank with the same diameter and length as the pump/motor assembly with electrical leads into the well to the desired depth. If there is any doubt about straightness, gagging and plotting are recommended.

### 4-2 PREPARING THE FOUNDATION

The foundation must be rigid, level and of adequate strength to support the complete weight of the pump, motor, column, plus the weight of the liquid passing through it. It is recommended the foundation be constructed of solid concrete, however, adequate beams or

timbers may be used. A common foundation consists of the following concrete mixture:

1. One part cement
2. Two parts sand
3. Four parts gravel
4. With sufficient water to make a stiff mix

### 4-3 MOTOR AND CABLE CHECKS AND PREPARATION

**CAUTION** DO NOT USE MOTOR LEADS TO LIFT OR HANDLE THE MOTOR. THE MOTOR LEADS ARE EASILY DAMAGED. THEY SHOULD BE PROTECTED AND HANDLED WITH CARE AT ALL TIMES.

#### 1. MOTOR SERVICING

Consult the motor manual and perform any preinstallation servicing that is required. Some motors may require filling with oil or water.

#### 2. ASSEMBLE OF MOTOR TO PUMP

If the pump and motor have not already been assembled, assemble per the instructions given in Appendix A. For extra long units, it may be more practical to assemble the pump to the motor in the vertical position at the installation site.

#### 3. TESTING BEFORE SPLICING POWER CABLE TO MOTOR LEADS

Perform the following tests before making the splice between the motor leads and the drop cable. Instructions for performing resistance tests and evaluating the results are given in Appendix C.

#### MOTOR TESTS

- Measure the resistance between each motor lead and ground with the motor submerged in water. *See Appendix C.*
- Measure the resistance of the motor windings. *See Appendix C.* Record the values for future reference.
- Secure the pump and motor with chain tongs to resist torque. Energize the motor momentarily (on and immediately off) to check the rotation.

**WARNING** GROUND THE UNIT WHEN TESTING. FAILURE TO GROUND THE UNIT PROPERLY CAN RESULT IN SERIOUS OR FATAL SHOCK. ALSO, THE HIGH STARTING TORQUE OF THE MOTOR WILL CAUSE IT TO 'KICK' WHEN POWER IS APPLIED. THE UNIT SHOULD BE RESTRAINED SUFFICIENTLY TO PREVENT DAMAGE TO THE EQUIPMENT OR PERSONAL INJURY.

**NOTE:** ROTATION WILL BE COUNTERCLOCKWISE WHEN VIEWED FROM THE DISCHARGED BOWL.

On three phase unit, if rotation is wrong, interchange any two of the motor leads at the control panel.

**CAUTION** CORRECT ROTATION IS OF EXTREME IMPORTANCE. EXCESSIVE OVERLOADS MAY BE DEVELOPED UNDER OPERATING CONDITIONS WITH REVERSE ROTATION.

## DROP CABLE TEST

- Measure the resistance between the cable conductors and ground with the cable submerged in water. *See Appendix C.*

## 4. SPLICING POWER CABLE TO MOTOR LEADS

A waterproof splice must be made to connect the power cable to the motor leads. A properly made splice will last the life of the pump. An improperly made splice will become a service problem. Make the splice per instructions supplied with the drop cable or per instructions in the pump motor manual. The splice should be located above the pump bowl. It should be as compact as possible. A compact splice is less likely to be damaged as the pump is being lowered into the well. *See Appendix B for instruction on splicing the cable.*

## 5. TESTING AFTER SPLICING POWER CABLE TO MOTOR LEAD

Perform the following test after making the splice, but before lowering the pump into the well.

- Check that the splice is waterproof by immersing it in a container of water for approximately one hour and then taking resistance readings between each cable conductor and the water. *See Appendix C.*
- Measure the total resistance of the complete drop cable and motor circuit to insure that a good splice was made. Record the values for future reference.

**CAUTION** THE MINIMUM READING FOR EACH LEAD TO GROUND SHOULD BE 50 MEGOHMS.

## SECTION 5 — INSTALLING THE PUMP

1. Check the pump and motor shaft to make sure it turns free before installation. For some models, it may be necessary to remove the suction screen in order to check the shaft. Be sure to reinstall the suction screen.
2. Raise the bowl/motor assembly with the shipping skids still in place. Remove the shipping skids and lower assembly into the well, clamping the bowl assembly near the top.
3. Attach the elevators to the bottom column pipe immediately below the column coupling. Hoist the column section into place above the well and the top of the bowl assembly, providing a soft board or pipe dolly for the end of the column pipe to slide in on so that threads will not be damaged while the section is being raised. Clean all threads with thread lubricant. Thread the pipe into the discharge bowl connection and make up tight, using one set of chain tongs for backup.

**CAUTION** THE PUMP MOTOR WILL EXERT A TORQUE THAT WILL TEND TO UNSCREW THREADED COLUMN PIPE CONNECTIONS. FOR THE REASON, THREADED COLUMN JOINTS MUST BE TIGHTENED.

THE FOLLOWING TABLE GIVES THE NORMAL AMOUNT OF THREAD ENGAGEMENT NECESSARY TO MAKE A TIGHT JOINT FOR THE NPT THREAD JOINT:

| Pipe Size | Length of Thread (in.) | Number of Threads |
|-----------|------------------------|-------------------|
| 3"        | 1"                     | 8                 |
| 4"        | 1 1/8"                 | 9                 |
| 5"        | 1 1/4"                 | 10                |
| 6"        | 1 5/16"                | 10 1/2            |
| 8"        | 1 7/16"                | 11 1/2            |
| 10"       | 1 5/8"                 | 13                |

4. Install a cable clamp on each side of the cable splice. *See Figure 1.* Be careful not to damage the cable. If an air line is to be installed, route it beside the cable, making sure that it is not pinched by the clamps. If there is any danger that the splice will rub against the well casing during installation, it should be protected by thick rubber chaffing pads or by a steel shield. Check that the grounding system is in place.

**WARNING** FAILURE TO GROUND THE UNIT PROPERLY CAN RESULT IN SERIOUS OR FATAL SHOCK. REFER TO ELECTRICAL CODE REQUIREMENTS.

5. Slowly lower the unit into the well (or sump) adding joints of column pipe as the unit is lowered. Tighten each joint securely. See note above. Remove slack from the power cable and attach a cable clamp approximately every 20 feet. For units with large heavy power cable, additional cable clamp may be required to give additional support. Line up the cable on one side of the pump and maintain as much clearance as possible on that side when lowering the pump in the well. **BE EXTREMELY CAREFUL NOT TO SCRAPE OR DAMAGE THE POWER CABLE, CABLE SPLICE OR GROUNDING SYSTEM WHEN LOWERING THE PUMP.** Hold the power cable up away from the well casing as lowering the pump into the casing.
6. If the pump does not have a built-in check valve, a line check valve should be installed within 25 feet above the pump bowl assembly. For a deep setting pump, a line check valve is recommended for every 200 feet of column pipe. However, **no check valve should be installed above the pumping level.**
7. As soon as the splice joint is submerged in the water, take a resistance reading between the power cable conductors and ground to assure that the insulation and the cable or the splice was not damaged during installation.
8. After the last piece of column pipe has been installed, install the well head. Install a cable clamp between the last column pipe coupling and the well head base. *See Figure 1.* Route the power cable and grounding system through the large threaded hole in the head base. Route the air line (if used) through one of the smaller threaded holes in the head base. The remaining small threaded hole is for connection of a well vent or other accessories. All of these holes are threaded with standard NPT or BSP pipe threads. If a gasket is required between the head base and its mounting surface, the gasket should be placed on the foundation prior to installing the well head.

9. After the well head has been properly tightened, carefully rotate the entire unit in the well until the discharge flange is facing in the desired direction. Push the unit to one side of the well, providing the maximum clearance for the drop cable when rotating the unit.
10. Slowly lower the well head onto its mounting surface. **BE CAREFUL NOT TO DAMAGE THE GROUNDING SYSTEM OR PINCH THE POWER CABLE BETWEEN THE SURFACE PLATE AND THE WELL CASING.** If a gasket or other seating device is used, be sure that it is aligned properly and that it is not damaged. Install the mounting bolts.
11. Before connecting the power cable to the control panel:

Take a resistance reading between the power cable conductors and ground to assure that the insulation on the cable or splice was not damaged during installation. *See Appendix C.*

Measure the resistance of the power cable and motor circuit. *See Appendix C.* Compare these readings with those taken in Section 4 to assure that the splice is still intact. Make the electrical connection between the power cable and the control panel. It may be desirable to use a terminal box at the well head to simplify the electrical work required when the pump is pulled. Be sure that the unit is grounded properly.

**⚠ WARNING** FAILURE TO GROUND THE UNIT PROPERLY CAN RESULT IN SERIOUS OR FATAL SHOCK. REFER TO ELECTRICAL CODE REQUIREMENTS.

Be sure to connect the leads as they were marked previously in the procedure.

## SECTION 6 — STARTING THE PUMP

**⚠ CAUTION** INITIAL STARTUP AND TESTING MAY REQUIRE STARTING AND STOPPING THE PUMP SEVERAL TIMES. BE SURE TO ALLOW ADEQUATE COOLING OFF PERIOD BETWEEN STARTS. CONSULT THE MOTOR MANUAL. IF NO INFORMATION IS GIVEN, A GOOD RULE-OF-THUMB IS TO ALLOW A MINIMUM OF 15 MINUTES BETWEEN STARTS.

For initial startup, allow the water to be pumped out onto the ground. A throttle valve in the discharge line is recommended. Position the throttle valve approximately one-fourth open for startup of the pump. This will prevent surging the well or the pump during startup.

If the pump has been in the well for several days before the startup, check the resistance between the cable conductor and ground to assure that water has not penetrated the splice or the cable insulation. *See Section 4.*

Clamp the tongs of a clamp-on type ammeter around one power lead to the pump. Set the ammeter on the maximum scale. After the motor starts, it can be reset to a lower scale as desired.

Refer to the motor manual and determine the normal operating amps for the installed motor.

Start the pump and observe and record the current readings on each conductor of the power lead. If the

current exceeds the normal value determined in the motor manual, stop the pump immediately. A high current reading indicates that something is wrong. Among the potential problems are:

- Incorrect pump rotation (3 phase only)
- Improper voltage
- Sand locked pump
- Improper cable size or leak in cable
- Mechanical damage

In any case, the problem must be corrected before the pump can be operated.

On three phase units, if water does not appear within one minute (deeper settings may require approximately one half minute per 100 feet setting) the motor may be running backwards. Stop the pump and interchange any two of the three cable connections. If there is any doubt about the proper rotation, run the motor in one direction and then the other. The rotation that gives the highest pressure and flow is always the correct one.

Check the voltage. The voltage when the pump is running should be within 5% of the pump motor nameplate voltage.

Open the throttle valve. If a flow meter is available, open the throttle valve to rated flow of the pump. If sand appears in the water, throttle the pump at approximately 80% of full flow until the sand clears. If excessive noise develops, pressure fluctuates or water appears foamy white, the pump is probably cavitating and the flow should be throttled until the noise diminishes, the pressure remains steady and the water is clear.

On three phase units, check for current unbalance. Details of the current unbalance test are given in Appendix C. **THE MAXIMUM ALLOWABLE CURRENT UNBALANCE IS 5%.** If the current unbalance exceeds 5% after rolling the leads and connecting them for the lowest unbalance, the pump should be stopped and corrective action taken. Current unbalance in excess of 5% can be expected to cause excessive heating in the motor and premature failure. Operation with a current unbalance in excess of 5% will void the warranty.

After the unit is operating properly, a performance test should be considered. If a performance test is conducted when the pump is new, subsequent tests can be used to determine the degree of wear or deterioration of the pump without removing it from the well. After the unit has been in operation for approximately one week, perform the routine tests.

## SECTION 7 — PUMP DISASSEMBLY AND REASSEMBLY

1. Clear a large area adjacent to the pump as storage space for pump parts as they are disassembled. If the pump has a long column, arrange parallel timbers on the ground to support the pump column horizontally. After disassembly for repair or replacement of pump components, reassemble in all cases in the reverse order of disassembly.

**NOTE: PUMP COMPONENTS SHOULD BE MATCH-MARKED PRIOR TO DISASSEMBLY.**

2. It is recommended that maintenance personnel become thoroughly familiar with the VS pump before performing any removal of the components. Consult the manufacturer's instructions for detailed disassembly information for the motor.

A. Remove the electrical connection at the conduit box and tag electrical leads at the motor.

**▲ WARNING** BEFORE OPENING THE CONDUIT BOX OF AN ELECTRICAL MOTOR, BE SURE THE CURRENT TO THE MOTOR IS SHUT OFF. SEVERE INJURY TO PERSONNEL COULD RESULT IF CONTACT WITH LIVE MOTOR LEADS IS MADE.

LOCK OUT SHOULD BE INSTALLED BEFORE ANY ELECTRICAL WORK IS PERFORMED.

NOTE: MATCH-MARK PARTS IN SEQUENCE OF DISASSEMBLY TO AID IN THE REASSEMBLY PROCEDURE.

B. Disconnect the discharge piping from the well head.

**▲ WARNING** DO NOT WORK UNDER A HEAVY SUSPENDED OBJECT UNLESS THERE IS A POSITIVE SUPPORT UNDER IT WHICH WILL PROTECT PERSONNEL SHOULD A HOIST OR SLING FAIL.

### 3. PUMP DISASSEMBLY

In the following pump disassembly procedures, references are made to installation sections of this manual. These sections will aid in the disassembly of the pump.

A. Disconnect well head and begin removal of column sections. *Refer to Section 5, #7.*

B. For removal of bowl/motor assembly, hoist the bowl/motor assembly from the well, using elevator clamps. Hoist in the same manner as for the column. For the keyed motor shaft, loosen the setscrews on the motor end of the shaft coupling. Remove the motor lead from the cable guard. Disassemble the bowl assembly from the motor by removing the connecting bolts at the flange joint. For the short assembly, laying the bowl/motor assembly on the ground to perform these works. For the long or large size assembly, it is recommended to perform these works while the assembly is in the vertical position. *Refer to Section 4, #3.* Proceed to disassemble the bowl assembly as follows.

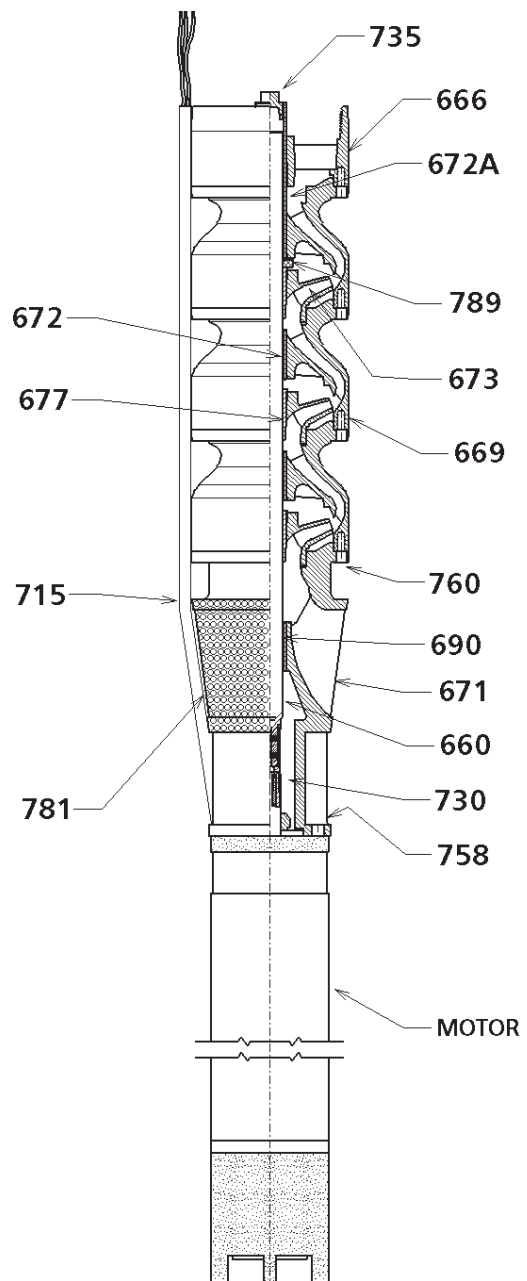

Figure 2 – Bowl and Motor Assembly

| ITEM | NAME                        | MATERIAL            | GPI  | ASTM          |
|------|-----------------------------|---------------------|------|---------------|
| 666  | Bowl Discharge              | Iron                | 1003 | A48 CL30      |
| 669  | Bowl - Intermediate         | Cast Iron - Glassed | 6911 | A48 CL30      |
| 672  | Bearing - Intermediate Bowl | Bronze              | 1109 | B584 C90300   |
| 672A | Bearing Discharge           | Bronze              | 1109 | B584 C90300   |
| 690  | Bearing Subadapter          | Bronze              | 1109 | B584 C90300   |
| 760  | Capscrews - Grade 8         | Steel               | 2298 | SAE J429 GR8  |
| 758  | Capscrews                   | SST 304             | 2228 | A276 S30400   |
| 730  | Coupling Motor              | SST 416             | 2218 | A582 S41600   |
| 715  | Guard Cable                 | SST 304             | 3215 | A240 S30400   |
| 673  | Impeller                    | Bronze              | 1102 | B584 C87600   |
| 781  | Screen Suction              | SST 304             | 3215 | A240 S30400   |
| 660  | Shaft                       | SST 416             | 2227 | A582 S41600   |
| 671  | Subadapter                  | Duct Iron           | 1018 | A536 65-45-12 |
| 677  | Taperlock                   | Steel               | 2242 | A108 G10180   |
| 789  | Washer Upthrust             | HDPE                | 6266 | Polyethylene  |
| 735  | Pipe Plug                   | Iron                | 1046 | A197          |

#### 4. BOWL DISASSEMBLY

The bowl assembly shown in Figure 2 is composed of a discharge bowl (for the model with built-in check valve, it would be column adapter), intermediate bowl, impellers with taper collects, motor adapter, bearings and pump shaft.

- A. Begin disassembly by removing the capscrews that secure the top stage intermediate bowl and the second stage intermediate bowl and slide the discharge and top intermediate bowls off the pump shaft together. Remove the thrust washer.
- B. Pull shaft out as far as possible and strike impeller hub utilizing a taperlock driver or equivalent sliding along the pump shaft to drive the impeller off the taperlock. See Figure 3.

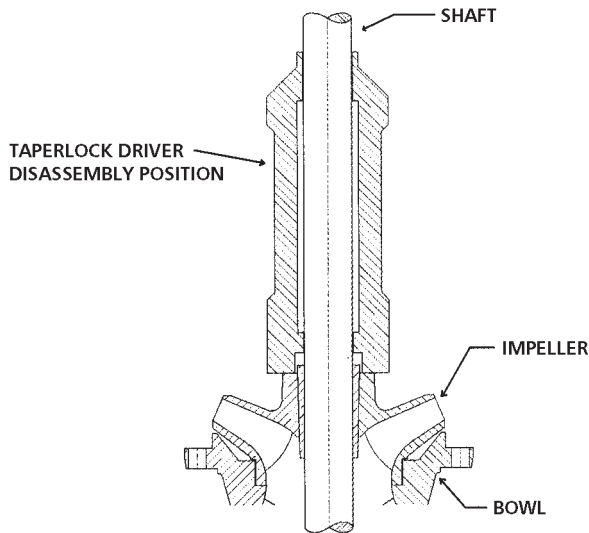

Figure 3 – Disassemble the Impeller

- C. After impeller is freed, insert a screwdriver into the taperlock to spread it. Slide taperlock and impeller off the pump shaft.
  - D. Use the preceding procedures until entire turbine bowl assembly is completely disassembled.
- #### 5. TURBINE BOWL – WEAR RINGS REMOVAL (OPTIONAL)
- A. Utilizing a diamond point chisel, cut two V-shape grooves on the bowl wear ring, approximately 180° apart. Use extreme care not to damage the wear ring seat.
  - B. With a chisel or equal, knock the end of half of the ring in and pry the ring out.
  - C. On special materials such as chrome steel, set up the bowl in a lathe and machine the wear ring off. Use extreme care not to machine or damage the ring seat.
- #### 6. TURBINE BOWL – IMPELLER WEAR RING REMOVAL (OPTIONAL)

Set up impeller in a lathe and machine wear ring out. Use extreme care not to machine or damage ring seat or impeller hub. Impeller wear ring may also be removed by following steps A and B, paragraph #5.

#### 7. BOWL BEARING REMOVAL

Utilizing an arbor press and a piece of pipe or sleeve with outside diameter slightly smaller than the bowl bearing diameter, press the bearing out.

#### 8. INSPECTION AND REPLACEMENT

- A. Clean all parts thoroughly with a suitable cleaner.
- B. Check bearing seats for deformation and wear.
- C. Check pump shaft for straightness and excessive wear on bearing surfaces. Check straightness of the pump shaft. The straightness should within 0.0005"/ft. TIR.
- D. Visually check impellers and bowls for cracks and pitting. Check all bowl bearings for excessive wear and corrosion.

#### 9. TURBINE BOWL AND IMPELLER WEAR RING INSTALLATION (OPTIONAL)

Place chamfered face of bowl or impeller wear ring towards the ring seat and press. Use an arbor press or equal. Make sure ring is flush with edge of wear ring seat.

#### 10. BOWL BEARING INSTALLATION

Press the bearing into all the bowls by using an arbor press or equivalent. Press the bearing in from the bottom end of the hub until the bottom end of the bearing is flush with the bottom end of the hub.

#### 11. TURBINE BOWL WITH TAPERLOCK – REASSEMBLY

- A. Secure the submersible assembly jig to the motor end of the motor adapter. See Figure 4. Be sure to use the proper jig for the motor frame size the bowl assembly is intended to adapt to.
- B. Put some grease in the suction bearing of the motor adapter. Slide the shaft through the bearing. Secure the shaft in place by locking the shaft to the assembly jig with a special long bolt or all thread and a hex nut. See Figure 4.

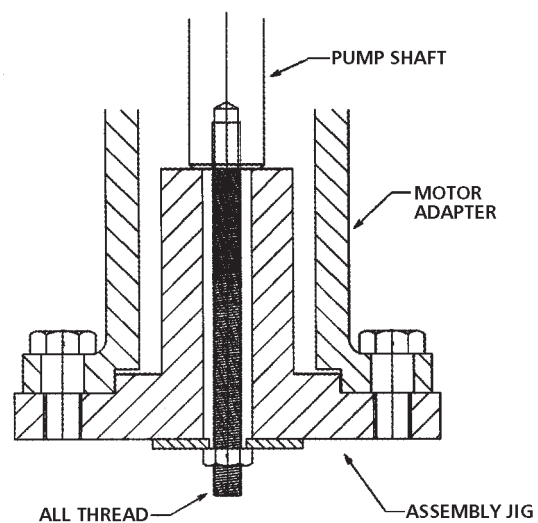

Figure 4 – Assembly Jig

- C. Slip impeller over the shaft. Then slip taperlock over the shaft with smaller end towards impeller. A screwdriver can be used to spread the taperlock for ease in slipping over the shaft.

D. Hold impeller firmly against the motor adapter and drive the taperlock into place with the taperlock driver. See Figure 5. After the impeller is secured in position, the top end of the taperlock should be 1/8" above the impeller hub.

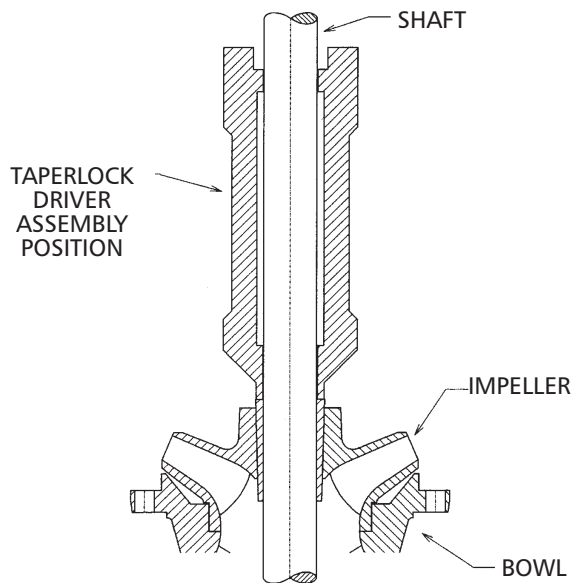

Figure 5 – Install the Impeller

- E. Put a little grease on the shaft where the intermediate bearing will be. Slip intermediate bowl over the shaft and bolt or screw it onto the motor adapter.
- F. Place the next impeller over the shaft and continue to assemble as explained above.
- G. After assembling the last impeller, slide the up-thrust washer over the shaft before assembling the top intermediate.
- H. Slide the discharge case and top intermediate bowl over the shaft and bolt it to the second intermediate bowl. If the pump has a built-in check valve, install the check valve before installing the discharge adapter.
- I. When the bowl is completely assembled, unlock the shaft and remove the assembly jig. Rotate the shaft by hand to see whether it rotates freely. Push the shaft all the way in and then pull it all the way out to check the lateral clearance. The lateral should be between 0.187" to 0.250".
- J. Install the square key in the keyway at the motor end of the pump shaft. Slide the shaft coupling over the shaft and secure it to the key with two setscrews.

## SECTION 8 — TROUBLESHOOTING CHART

In case of difficulties, refer to the chart to locate basic problems with the system. Once the problem is located, refer to specific sections in this manual for details.

| CONDITION              | PROBABLE CAUSE  | REMEDY  |
|------------------------|---|---|
| PUMP WILL NOT RUN      | <ol style="list-style-type: none"> <li>1. Motor overload protector trip               <ol style="list-style-type: none"> <li>a. Incorrect control box.</li> <li>b. Incorrect connections.</li> <li>c. Faulty overload protector.</li> <li>d. Low voltage.</li> <li>e. Ambient temperature of control box or starter too low.</li> <li>f. Pump bound by foreign matter.</li> </ol> </li> <li>2. Blown fuse, broken or loose electric connections.</li> <li>3. Motor control box or starter not in proper position.</li> <li>4. Cable insulation damaged.</li> <li>5. Splice may be open or grounded.</li> <li>6. Faulty pressure switch.</li> <li>7. Faulty liquid level control.</li> </ol> | <ol style="list-style-type: none"> <li>1. Allow motor to cool, overload will automatically reset. Investigate cause of overload.               <ol style="list-style-type: none"> <li>a-e. Have a qualified electrician inspect and repair, as required.</li> <li>f. Pull the pump, examine and clean. Adjust set depth as required.</li> </ol> </li> <li>2. Check fuses, relays or heater elements for correct size capacitor and all electrical connections.</li> <li>3. Make sure box is in upright position.</li> <li>4. Locate and repair as per instructions.</li> <li>5. Check resistance between cable leads with ohmmeter. If open or grounded, pull pump and resplice.</li> <li>6. Repair or replace.</li> <li>7. Check relay, wires and electrodes.</li> </ol> |
| PUMP RUNS BUT NO WATER | <ol style="list-style-type: none"> <li>1. Line check valve backward.</li> <li>2. Pump is air-bound.</li> <li>3. Lift too high for the pump.</li> <li>4. Suction screen or impeller plugged, or pump in mud or sand.</li> <li>5. Pump not submerged.</li> <li>6. Well may contain excessive amounts of air or gas.</li> <li>7. Three-phase unit running backwards.</li> </ol>  | <ol style="list-style-type: none"> <li>1. Reverse check valve.</li> <li>2. Successively start and stop pump until water flows normally.</li> <li>3. Review performance requirement.</li> <li>4. Pull the pump and clean, check well depth. Raise setting if necessary.</li> <li>5. Check water level. Lower pump if permissible.</li> <li>6. Start and stop pump several times. If this does not remedy conditions, pump may not be able to cooperate because of too much gas in the well.</li> <li>7. Reverse rotation.</li> </ol>   |

## SECTION 8 — TROUBLESHOOTING CHART (continued)

| CONDITION                                      | PROBABLE CAUSE   | REMEDY   |
|--|--|--|
| REDUCED CAPACITY OR INSUFFICIENT TANK PRESSURE | <ol style="list-style-type: none"> <li>1. Lift too high for the pump.</li> <li>2. Screen or impellers partly plugged.</li> <li>3. Scaled or corroded discharge pipe or leaks anywhere in system.</li> <li>4. Well may contain excessive amounts of air or gas.</li> <li>5. Excess wear due to abrasives.</li> <li>6. Three-phase pump running backward.</li> </ol> | <ol style="list-style-type: none"> <li>1. Check rating.</li> <li>2. Pull pump and clean.</li> <li>3. Replace pipe and repair leaks.</li> <li>4. Start and stop pump several times. If this does not remedy conditions, pump may not be able to cooperate because of too much gas in the well.</li> <li>5. Replace worn parts.</li> <li>6. Reverse rotation.</li> </ol> |
| PRESSURE SWITCH DOES NOT CUT OUT               | <ol style="list-style-type: none"> <li>1. Incorrect set.</li> <li>2. Switch opening plugged.</li> <li>3. Leaks anywhere in system.</li> <li>4. Three-phase pump running backward.</li> </ol>   | <ol style="list-style-type: none"> <li>1. Change settings.</li> <li>2. Pull pump and clean.</li> <li>3. Repair leaks.</li> <li>4. Reverse rotation.</li> </ol>   |
| PUMP STARTS TOO FREQUENTLY                     | <ol style="list-style-type: none"> <li>1. Water-logged tank.</li> <li>2. Check valve leaking.</li> <li>3. Pressure switch out of adjustment.</li> <li>4. Leaks in service line.</li> </ol>   | <ol style="list-style-type: none"> <li>1. a. Check tank for leaks (plug at top of tank may be leaking air).<br/>b. Be sure drain and 'Y' fittings are functioning properly. Check operation of snifter valve.</li> <li>2. Replace check valve.</li> <li>3. Readjust to correct setting or replace.</li> <li>4. Locate and correct.</li> </ol>                          |

### APPENDIX A — ASSEMBLY OF PUMP AND MOTOR

Most of the time, the pump and the motor are shipped separately in two different boxes. They need to be assembled together in the field prior to being installed in the well. For the short pump (less than 5 stages), the motor and pump may be assembled together on the ground horizontally. If the pump is over 6 stages long, it is recommended to assemble them in the vertical position.

1. Check that the pump shaft and the motor shaft turn freely.
2. Clean the flange faces and the registers on the pump and the motor. Remove all burrs from these areas. Clean the exposed portion of the pump shaft and motor shaft. If the pump is supplied with the coupling assembled on the shaft, clean the inside of the motor-end of the coupling.
3. Install the key on the motor shaft, if it is not the splined shaft.
4. If the shaft coupling has setscrews in the motor half of the coupling, loosen or remove these setscrews.
5. Align the motor with the pump and slide the motor shaft into the shaft coupling on the pump until the shaft butts. **Make sure the motor shaft lifts the pump shaft by 1/8" to 1/4" (for enclosed impeller only).** Be careful not to damage the shaft, the coupling or the key. Orient the motor so that the motor leads are aligned with the notch provided in the pump's mounting flange. If the shaft coupling has setscrews in the motor half the coupling, install and tighten the setscrews.
6. Install and tighten the mounting bolts (or capscrews) on the flange.

7. Unite the cableguard on the pump and reassemble it with the motor leads under the cableguard to prevent damaging the leads, when lowering the pump into the well.

### APPENDIX B — SPLICING POWER CABLE TO MOTOR LEADS

A waterproof splice must be made to connect the power cable to the motor leads. A properly made splice will last the life of the pump. An improperly made splice will become a service problem. In the market, there are different materials and methods to make waterproof cable splices. For example: by waterproof tapes, by resin castings, by heat shrink tubes.

#### TAPED CABLE SPLICE:

1. Strip the insulation of each conductor of the power cable back enough to allow the conductor to extend half way through a sleeve type connector. Crimp connector to the conductor. Strip the insulation of the motor lead same as the power cable. Fit it into the connector and butt against cable end. Crimp connector as before. Pull on wire to make sure connector is firmly crimped to both the motor lead and the power cable. Scrape the insulation to move any loose bits of tape or thread and roughen surface. Thoroughly clean surface with solvent. This will insure a watertight splice.
2. Tape individual joints with rubber electrical tape. Start at the center of the connector and tape 2" past the end of conductor insulation end. Stretching tape about 10% while taping, overlap tapes about one half of tape width. Make two layers. The end of second layer should be 2" beyond the end of the first layer.
3. Tape over the rubber electrical tape with #33 Scotch electrical tape or equivalent, using two layers as in step #2 and making each layer overlap the end of the preceding layer by 2".

## CAST CABLE SPLICE:

1. To prepare the 3-conductor power cable for splicing, insert a sharp knife blade between the cable jacket and lead insulation and strip the jacket back 2<sup>1</sup>/<sub>2</sub>" from the end. Taking care not to cut the lead insulation. Strip the cambric wrapping (if any) off the conductors and strip back rubber insulation <sup>5</sup>/<sub>8</sub>" from the end. Assemble the cable connectors and crimp them in place using a crimping tool.
2. Cut off the motor leads to equal length. Clean off the ends of the leads for about a foot, using a cloth wet with gasoline or solvent. Clean the end of the power cable also. Insert the three motor leads into the corresponding holes in the bottom of the rubber casing and push them several inches out the top. Crimp the motor leads into the corresponding connectors, crimping the center one first. Bend the cables into line with the holes in the casing and slip the casing up until the connectors are inside the holes and about <sup>1</sup>/<sub>4</sub>" from the top.
3. Mix the resin as directed. Cut off a corner of the bag and squeeze all of the resin into casing. With the roll of tape on hand, fold the bag and tape the top of the bag snugly to the power cable until the resin runs out over the top. This will assure maximum coverage of the resin and minimum size of the finished splice. When the resin is firm to touch, the splice may be immersed for testing.

## APPENDIX C — ELECTRICAL TESTS

### 1. MEASURING INSULATION RESISTANCE (GROUND TEST)

The condition of the insulation around a conductor can be determined by measuring the electrical resistance between the conductor and ground. This measurement can be made with a megger or an ohmmeter. The value is stated in ohms or megohms (ohms x 1,000,000). High ohm values indicate good insulation.

The basic procedure for measuring insulation resistance is given below:

- A. Turn off all power and disconnect the leads to be tested from the electrical panel. **Lock out the panel.**

**▲ WARNING** FAILURE TO TURN OFF THE POWER WILL DAMAGE THE METER AND CAN CAUSE SERIOUS OR FATAL SHOCK.

Failure to disconnect the leads can result in false readings.

- B. Set the meter selector knob to RX 100K or RX 100,000 (some meters may not have RX 100K in which case EX 10K or EX 10,000 scale can be used). Clip the meter leads together and adjust the meter to zero.
- C. Unclip the leads and attach one of the meter leads to one of the power cable leads or motor leads. The other meter to the ground.
- D. Do not touch any bare wires or allow bare wires to come in contact with the ground or metal. False readings will result.

- E. If the meter needle is at either extreme end of the scale, a more accurate reading can be obtained by switching the selector switch to another scale. Rezero the meter each time the selector switch is moved.

The readings obtained from power cables and motor leads should be within the range specified in Table C.1. Low readings indicate that the motor windings are grounded or that the cable or splice insulation is damaged. If low or marginal readings are obtained on a new installation the problem should be corrected before proceeding with the installation.

### 2. MEASURING RESISTANCE BETWEEN LEADS (MOTOR WINDING RESISTANCE)

The general conditions of motor windings can be determined by measuring the resistance of the motor windings (i.e. the resistance between the motor leads) and comparing the measured resistance with values given in the motor manual. The resistance is measured with an ohmmeter and the value is stated in ohms.

The basic procedure for measuring motor winding resistance is given below:

- A. Turn off the power and disconnect the leads to be tested from the panel. **Lock out the panel.**

**▲ WARNING** FAILURE TO TURN OFF THE POWER WILL DAMAGE THE METER AND CAN CAUSE SERIOUS OR FATAL ELECTRICAL SHOCK.

Failure to disconnect the leads can result in false readings.

- B. Set the meter selector knob to 'RX 1'. Clip the meter leads together and adjust the meter to zero.
- C. Unclip the meter leads and attach them to the motor leads.

Resistance measured between the motor leads prior to splicing the power cable to the motor leads should be within the motor winding resistance limits specified in the motor manual.

**TABLE C.1 — NORMAL INSULATION RESISTANCE VALUES BETWEEN ALL LEGS AND GROUND**

Insulation resistance does not vary with rating. Motors of all HP, voltage and phase rating have the same insulation resistance ranges.

| CONDITION OF MOTORS AND LEADS   | OHMS   | MEGOHMS  | METER READING                            |                                      |
|---|--|--|--|--------------------------------------|
|   |  |  | R x 100K<br>or<br>R x 100,000<br>Scale   | R x 10K<br>or<br>R x 10,000<br>Scale |
| <b>BENCH TESTS</b> <ul style="list-style-type: none"> <li>• A new motor (without drop cable).</li> <li>• A used motor which can be reinstalled in the well.</li> <li>• Cable splice after immersion for one hour in water.</li> </ul>   | 20,000,000+<br>10,000,000+<br>2,000,000+   | 20+<br>10+<br>2+                                 | 200+<br>100+<br>20+                      | 2000+ or 2K+<br>1000+ or 1K+<br>200+ |
| <b>WELL TESTS</b> Ohm readings are for drop cable plus motor. <ul style="list-style-type: none"> <li>• A new motor or used motor in good condition.</li> <li>• A motor in reasonably good condition.</li> <li>• A motor which may have been damaged by lightning or with damaged leads. Do not pull the pump for this reason.</li> <li>• A motor which definitely has been damaged or with damaged cable. The pump should be pulled and repairs made to the cable or the motor replaced. The motor will not fail for this reason alone, but will probably not operate for long.</li> <li>• A motor which has failed or with completely destroyed cable insulation. The pump must be pulled and the cable repaired or the motor replaced.</li> </ul> | 2,000,000+<br>500,000–2,000,000<br>20,000–500,000<br>10,000–20,000<br>Less than 10,000 | 2+<br>0.5–2.0<br>0.02–0.5<br>0.01–0.02<br>0–0.01 | 20+<br>5–20<br>0.2–5<br>0.1–0.2<br>0–0.1 | 200+<br>50–200<br>2–50<br>1–2<br>0–1 |

+ Indicates that the reading should be the value shown or greater. Higher readings indicate better insulation.

Resistance measured between the power cable leads after splicing the power cable to the motor leads will indicate the resistance of the power cable plus the motor windings. The motor winding resistance is obtained by the formula below. The calculated value should be within the limits specified in the motor manual.

$$\text{Motor Winding Resistance} = \text{Reading taken at Power Cable} - \text{Cable Resistance from Table 2.}$$

A higher winding resistance than shown in the motor manual indicates a possible burned (open) winding, an open cable, a loose connection or the wrong motor (different HP or voltage than readings being referenced).

A considerably lower winding resistance than shown in the motor manual indicates a possible shorted (burned together) winding or the wrong motor.

Unequal resistance between the windings on a three phase motor indicates a burned winding or a faulty connection.

## TABLE C.2 — POWER CABLE RESISTANCE

The values below are for copper conductors. If aluminum conductor drop cable is used, the resistance will be higher for each foot of cable of the same size. To determine the actual resistance of aluminum drop cable, divide the ohm readings from this chart by 0.61. This chart shows total resistance of cable from control box to motor and back.

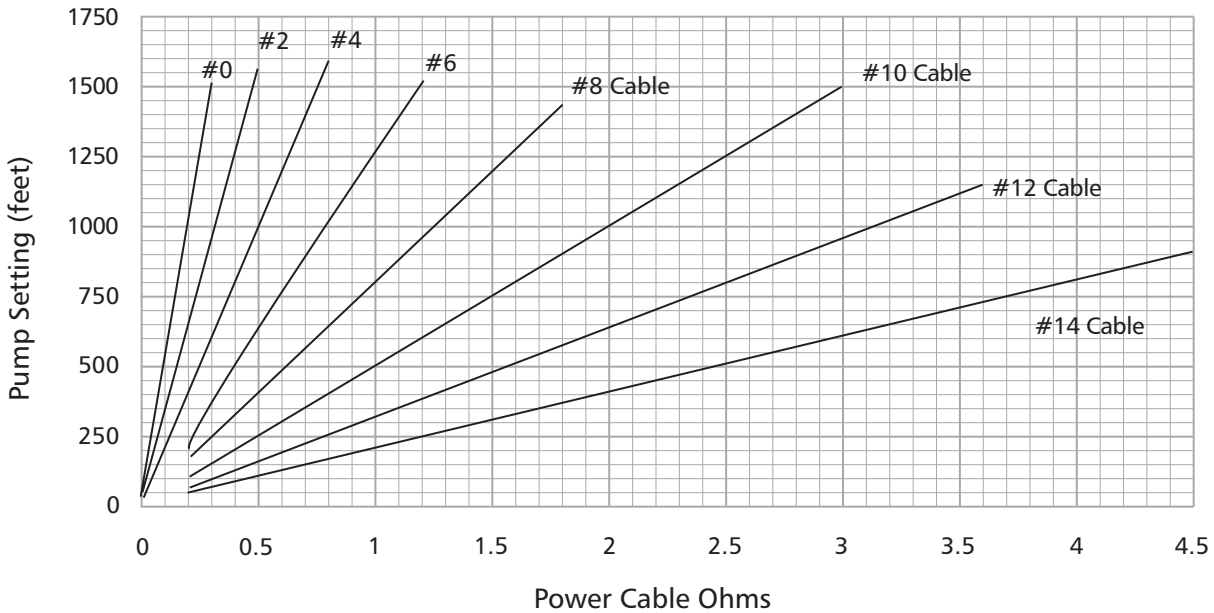

### 3. CURRENT UNBALANCE TEST:

A. For three phase units, after correct rotation has been established, check the current in each of the three motor leads and calculate the current unbalance as explained below. If the current unbalance is 2% or less, leave the leads as connected. If the current unbalance is over 2%, current readings should be checked on each leg using one of three possible hook-ups indicated in the table below. Roll the motor leads across the starter in the same direction to prevent motor rotation reversal. This procedure

is commonly known as "rolling the leads". THE HOOKUP THAT RESULTS IN THE LOWEST PERCENT CURRENT UNBALANCE SHOULD BE USED FOR THE FINAL CONNECTION OF THE POWER LEADS.

B. Current unbalance is determined by measuring the amperage of each of the three legs and then calculating the percent current unbalance using the formula below. This calculation must be performed using each of the three hookups shown.

$$\text{Percent Current Unbalance} = \frac{\text{Maximum Current difference in any leg from average current}}{\text{Average Current}} \times 100$$

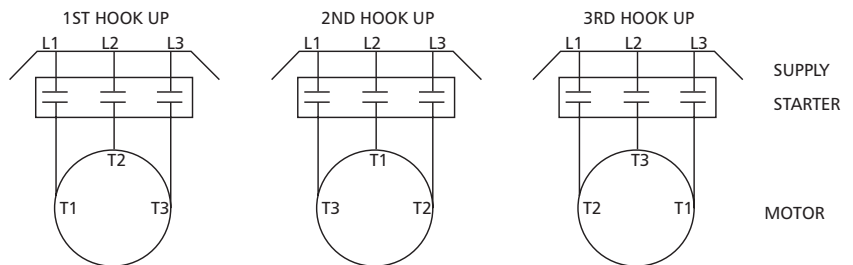

|   | Sample Calculation                              |   |   |   |
|---|---|---|---|---|
| • Measure current in each leg.                                  | T1 L1 51 amps<br>T2 L2 46 amps<br>T3 L3 53 amps | T1 L1 _____<br>T2 L2 _____<br>T3 L3 _____                               | T3 L1 _____<br>T1 L2 _____<br>T2 L3 _____                               | T2 L1 _____<br>T3 L2 _____<br>T1 L3 _____                               |
| • Add leg currents to determine total current.                  | 150 amps  |   |   |   |
| • Calculate average leg current.                                | $\frac{150}{3} = 50$ amps                       | $\frac{\quad}{3}$   | $\frac{\quad}{3}$   | $\frac{\quad}{3}$   |
| • Determine maximum difference of any one leg from the average. | 51 - 50 = 1<br>50 - 46 = 4 ← max<br>53 - 50 = 3 | _____ - _____ = _____<br>_____ - _____ = _____<br>_____ - _____ = _____ | _____ - _____ = _____<br>_____ - _____ = _____<br>_____ - _____ = _____ | _____ - _____ = _____<br>_____ - _____ = _____<br>_____ - _____ = _____ |
| • Calculate percent unbalance using formula above.              | $\frac{4}{50} \times 100 = 8\%$                 | _____ x 100 = %   | _____ x 100 = %   | _____ x 100 = %   |



*A division of Layne Christensen Company*

C. THE CURRENT UNBALANCE BETWEEN LEGS SHOULD NOT EXCEED 5% at service factor load or 10% at rated input load. If the unbalance cannot be corrected by rolling leads, the source of the unbalance must be located and correct.

D. By observing where the furthest current reading from the average is for each leg of each of the hookups, the cause of the unbalance can be determined. If the leg furthest from average is always on the same motor lead, the primary source of unbalance is on the "motor side" of the starter. In this instance, consider a damaged cable, leaking splices, poor connection or faulty motor winding.

#### LIMITED WARRANTY

This warranty applies to all water systems pumps manufactured by Layne Christensen.

Any part or parts found to be defective within the warranty period shall be replaced at no charge to the dealer during the warranty period. The warranty period shall exist for a period of twelve (12) months from date of installation or eighteen (18) months from date of manufacture, whichever period is shorter.

A dealer who believes that a warranty claim exists must contact the authorized Layne Christensen distributor from whom the pump was purchased and furnish complete details regarding the claim. The distributor is authorized to adjust any warranty claims utilizing the Layne Christensen Customer Service Department.

**The warranty excludes:**

- (a) Labor, transportation and related costs incurred by the dealer;
- (b) Reinstallation costs of repaired equipment;
- (c) Reinstallation costs of replacement equipment;
- (d) Consequential damages of any kind; and,
- (e) Reimbursement for loss caused by interruption of service.

**For purposes of this warranty, the following terms have these definitions:**

- (1) "Distributor" means any individual, partnership, corporation, association, or other legal relationship that stands between Layne Christensen and the dealer in purchases, consignments or contracts for sale of the subject pumps.
- (2) "Dealer" means any individual, partnership, corporation, association, or other legal relationship which engages in the business of selling or leasing pumps to customers.
- (3) "Customer" means any entity who buys or leases the subject pumps from a dealer. The "customer" may mean an individual, partnership, corporation, limited liability company, association or other legal entity which may engage in any type of business.

**THIS WARRANTY EXTENDS TO THE DEALER ONLY.**